

CASE HOLDER BASE

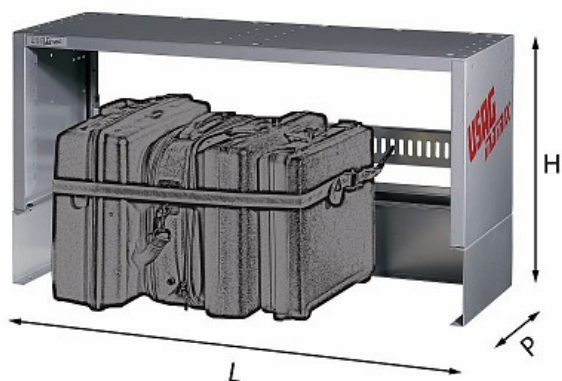

5002 E2

- Belt-type case holder
- Belt in syntetic anti-graze material
- Inside available dimensions L920xD340xH510 mm
- Supplied with case bar 5002 EB and belt 5002 EC

Family details

Code	LxPxH mm	Weight kg	Quantity for packaging
U50020024	990x375x542	11,7	1

Stanley Black & Decker Italia S.r.l.

Sede legale: Via Energy Park 6 - 20871 Vimercate (MB)
Sede operativa: Via Volta 3 - 21020 Monvalle (VA) Italia
Partita IVA e C.F.: 03225990138

StanleyBlack&Decker

Società a Socio Unico soggetta a coord. e controllo da parte di Stanley Black & Decker, Inc.
Capitale Sociale I.V. € 12.000.000